

**NEW!**

## Abrasive Metering System

# FEEDLINE PRECISION

## Variable Control Dial for Precision and Flexibility!



**Dial-It-In Abrasive Control Knob---Adjusts While Cutting**

*An accurate and consistent abrasive feed-rate is critical to the waterjet abrasive cutting process. A well regulated feed-rate of abrasive cuts down on waste and results in a tighter cutting stream with a cleaner, smoother cutting edge.*

KMT Waterjet Systems introduces the New FEEDLINE PRECISION variable dial control abrasive vessel. The full spectrum dial, notched in 1/10 lb. increments, delivers precise flow control of abrasive from 0 to 2-1/2 lbs./min. for cutting a variety of materials and thicknesses. The innovative *Dial-It-In* feature delivers flexible, economical and accurate delivery of abrasive to the cutting nozzle.

### KMT Knows Accuracy & Precision

The FEEDLINE PRECISION Abrasive Metering System is designed with the same precision engineering KMT Waterjet has been globally known for since 1971 when they invented the first waterjet cutting system.

### Ease of Use & Maintenance

The KMT FEEDLINE PRECISION is simple to mount, operate and maintain. The gravity fed abrasive automatically feeds to the fill line. ***No need to pause the cutting process--the abrasive feed-rate can be adjusted to increase or decrease the abrasive stream.*** Adjusting the abrasive feed is quickly done by the operator with a turn of the knob to the correct setting.

### Flexibility in Abrasive Use & Cutting Speed

The KMT FEEDLINE PRECISION features an accurate dial with multiple settings, from 0 to 2-1/2 lbs./min., which allow the operator to quickly select the amount of abrasive needed to improve cutting speed. The orifice setting is easily viewed by the operator at any time.

### Compact & Lightweight

The KMT FEEDLINE PRECISION measures approximately 13.03" x 5.17" and is constructed of primarily lightweight, durable non-metallic composites that will not corrode in most environments.

### Designed to Minimize Down Time

The KMT FEEDLINE PRECISION features tightly sealed O-rings at the top and bottom of the abrasive housing, as well as the metering assembly to prevent moisture from contaminating the abrasive. The abrasive outlet feed is designed to help inhibit water from entering the housing and cause slowing, or possible clogging, of abrasive feed and the metering assembly is removable for easy cleaning.

### The KMT Waterjet Family of Products

The FEEDLINE PRECISION is designed to work with the complete line of KMT Waterjet cutting head components and the STREAMLINE™ SL-V line of pumps, including the new, fastest cutting STREAMLINE™ PRO 100,000 PSI pump.

Please call to discuss your applications or to receive more information on any high pressure component. KMT Waterjet has a network of trained and certified technicians available to provide Cutting Edge Solutions.



## Summary of Features

- **KMT FEEDLINE PRECISION:** Simplicity and Flexibility for Performance Value.
- **Operational Ease:** The FEEDLINE PRECISION from KMT is a performance value abrasive feeder that can be adjusted while cutting for maximum efficiency.
- **Cutting Flexibility:** Large, easy to read variable dial control knob is notched in 1/10 lb./min. increments for precision control---operator can quickly determine the amount of abrasive needed to improve cutting speed.
- **Consistent Accuracy:** Hardened orifice components minimize changes in feed-rate over time due to orifice wear.
- **Simplified Technology:** Gravity feed design close to the KMT Autoline™ or IDE™ cutting heads eliminates abrasive waste.
- **Non-Metallic Design:** Lightweight, durable non-metallic construction for easy cleaning and corrosion resistance. Clear 360 degree viewing of abrasive for easy monitoring.
- **Wear Components:** Air cylinder rod shielded to minimize wear from abrasive. Fast and easy part replacement. Fast and easy cleaning, no tools required for day-to-day maintenance.

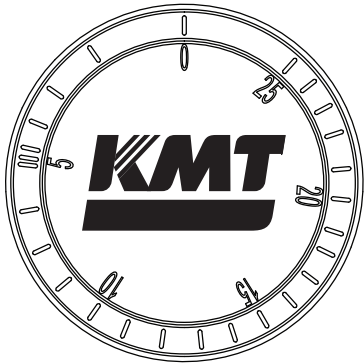

**Dial-It-In Abrasive Control Knob**  
Notched in 1/10 lb. increments for precision control

### Legend

- 1 - Air Connection (Abrasive OFF)
- 2 - Air Connection (Abrasive ON)
- 3 - Abrasive Inlet
- 4 - Abrasive Housing
- 5 - Variable Dial Knob
- 6 - Abrasive Housing Base
- 7 - Metering Assembly Knob
- 8 - Abrasive Outlet to Cutting Head

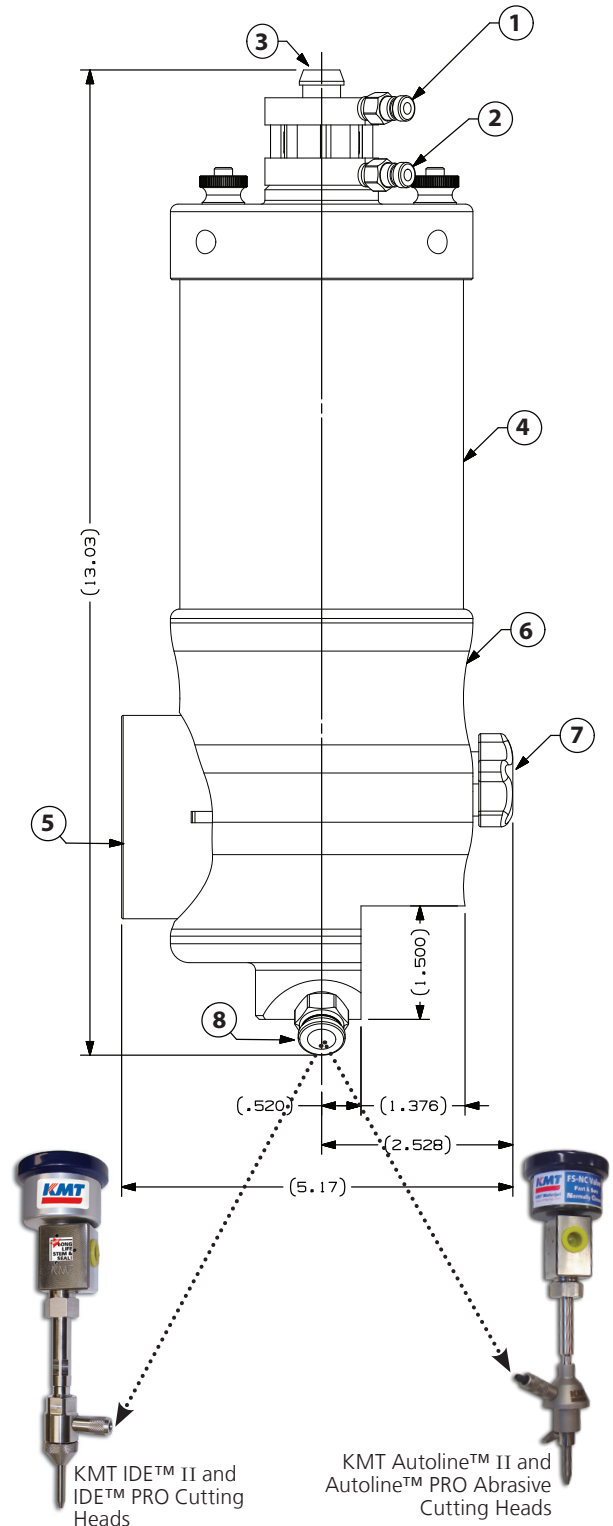

KMT Waterjet Systems Inc.

635 W. 12th Street • P.O. Box 231 • Baxter Springs, KS 66713  
Tel.: 1-620-856-2151 • Fax: 1-620-856-5050  
[www.kmtwaterjet.com](http://www.kmtwaterjet.com) • [sales@kmtwaterjet.com](mailto:sales@kmtwaterjet.com)

